

Mobile Telephone **MM35D** USER MANUAL



Reading the User Manual prior to using the phone is highly recommended.

1	INTRODUCTION	6
2	TECHNICAL SPECS:	7
3	THE SET INCLUDES	7
4	ACCESSORIES	8
5	IMPORTANT SAFETY PRECAUTIONS	8
6	GETTING STARTED	10
6.1	SIM CARD AND BATTERY INSTALLATION	10
6.1.1	<i>Desktop Charger</i>	13
7	LOW BATTERY ALERT	13
8	PHONE DESCRIPTION	14
8.1	DISPLAY SCREEN DESCRIPTION.....	17
8.2	KEYPAD LOCK	18
9	USING MENU	18
10	PHONEBOOK	18
10.1.1	<i>Saving New Entries</i>	18
10.2	VIEWING PHONEBOOK	19
10.3	DELETING ENTRIES	20
10.3.1	<i>Deleting a Single Contact</i>	20
10.3.2	<i>Deleting All Contacts</i>	20
10.4	COPYING CONTACTS	20
10.4.1	<i>How to Copy a Single Contact</i>	20
10.4.2	<i>How to Copy All Contacts</i>	21
10.5	TRANSFERRING CONTACTS	21
10.6	PHONEBOOK SETTINGS.....	21
10.6.1	<i>Memory Status</i>	21
10.6.2	<i>Speed Dial</i>	21
10.6.3	<i>Additional Numbers</i>	22
11	MAKING PHONE CALLS	22
11.1	DIRECT DIALING.....	22
11.2	DIALING NUMBERS FROM THE PHONEBOOK	23

11.3	DIALING NUMBERS FROM THE CALL LOG	23
11.4	SPEED DIAL	23
11.5	ADJUST PHONE CALL VOLUME	23
11.6	OPTION WHILE TALKING	23
11.7	CALL TRANSFER	24
11.8	ANSWERING PHONE CALLS	24
12	CALL LOG	24
13	TEXT MESSAGES	25
13.1	CREATING & SENDING TEXT MESSAGES	26
13.2	READING & REPLYING TO TEXT MESSAGES	26
13.3	TEXT MESSAGES BOXES	27
13.3.1	<i>Inbox</i>	27
13.3.2	<i>Drafts</i>	27
13.3.3	<i>Outbox</i>	27
13.3.4	<i>Sentbox</i>	27
13.4	DELETING MESSAGES	28
13.5	MESSAGE SETTINGS	28
13.6	VOICEMAIL	28
14	TOOLS.....	29
14.1	CALENDAR.....	29
14.2	CALCULATOR	29
14.3	AUDIO PLAYER	30
14.4	PHOTO VIEWER.....	30
14.5	VOICE RECORDER	31
14.6	FILE MANAGER	31
14.7	NETWORK SERVICES.....	32
14.8	SIM SERVICES.....	32
15	ALARM	32
16	RADIO FM.....	32
17	SETTINGS.....	33

17.1	SETTING DATE AND TIME.....	33
17.2	PROFILES	34
17.3	LANGUAGE	34
17.4	DISPLAY SCREEN.....	35
17.4.1	<i>Wallpaper</i>	35
17.4.2	<i>Automatic Keypad Lock</i>	35
17.4.3	<i>Backlight</i>	35
17.4.4	<i>Brightness</i>	35
17.5	SECURITY SETTINGS	35
17.5.1	<i>PIN Code</i>	35
17.5.2	<i>Phone Securities</i>	36
17.6	CALL SETTINGS	36
17.6.1	<i>Number Withhold</i>	36
17.6.2	<i>Call Waiting</i>	36
17.6.3	<i>Call forwarding</i>	36
17.6.4	<i>Call Barring</i>	37
17.6.5	<i>Black List</i>	37
17.6.6	<i>Call Duration Reminder</i>	38
17.6.7	<i>Auto Redial</i>	38
17.6.8	<i>Answered Phone Alert</i>	38
17.6.9	<i>Answering Calls</i>	38
17.7	NETWORK SETTINGS.....	38
17.8	FLIGHT MODE	38
17.9	RESTORE FACTORY SETTINGS.....	39
18	COMPUTER CONNECTION	39
19	FAQ (TROUBLESHOOTING)	39
20	WARRANTY TERMS	42
21	BATTERY INFORMATION	42
22	SAR INFORMATION	43
23	PROTECT YOUR ENVIRONMENT	45
24	EC DECLARATION OF CONFORMITY.....	46

If any device malfunction is detected, please contact the Maxcom technical support, or file a complaint at the point of sale.

Direct phone number:

+ 48 32 325 07 00

Note: The phone works in the GSM 900/1800 MHz. At least one SIM Card must be correctly inserted prior to switching on the phone

1 INTRODUCTION

Thank you for purchasing the Maxcom telephone. Our telephones are designed for the GSM network, and meet all European standards. The phone might be used in various networks, depending on roaming settings provided by your service provider. In order to be able to use the phone, the User must select GSM service provided by a service provider. The phone has a lot of great features; how well it works, however, depends on service available in the GSM network of your choice.

To learn more, contact your service provider.

This User Manual has been published by the Manufacturer. Corrections and modifications arising from errors, and inaccuracies in current information and advancing the phone or software might be made at any time without prior notice; such updates, however, will be reflected in future versions of the User Manual. For more information or any assistance go to our website at www.maxcom.pl.

The Manufacturer reserves their rights to any content of this Manual.

Copyrights and trademarks as mentioned in this document remain the property of their owner. Copying, forwarding, storing or dissemination of its content, either whole or partial, without prior written authorization is prohibited.

2 TECHNICAL SPECS:

- Color display TFT 1,77" (160x128)
- Big font, easy Menu
- Big backlit keys
- Phone book -500 entries
- SMS Memory – 500 entries
- Micro SD Card Service up to 16 GB
- Speakerphone
- Radio FM
- Alarm Clock
- Audio File Player
- Battery: 1000mAh
- Desktop Charger
- Idle time: up to 300 hrs*
- Conversation time: up to 10 hrs.*
- Dimensions: 145 X 52 X 14mm
- Weigth: 86g

*depending on the GSM network conditions and signal

3 THE SET INCLUDES

GSM Telephone
Charger
Desktop Charger
Battery
User Manual
Warranty Card

Note: Keeping the original package is recommended as it might be used for transport.

Keep the receipt as it is necessary for warranty.

4 ACCESSORIES

Use only batteries, chargers, and accessories as recommended by the Manufacturer of this phone. Check with your seller what accessories are available in your area.

5 IMPORTANT SAFETY PRECAUTIONS

Reading the guidelines below will minimize the risk of misusing the phone.

- **USING** – The telephone emits electromagnetic field that might negatively interfere with other electronic devices including medical equipment.
- Never use your phone in any area where the use of mobile phones is prohibited such as hospitals, airplanes, refueling points or at proximity to flammable materials. Using mobile phones in such places might expose others to danger.
- Never use the phone without suitable accessories while driving.
- A device and its accessories might contain small parts. Keep your phone and all parts out of reach of children.
- **SERVICE** - Never repair nor modify your phone by your own; any repairs should be made by authorized service only.
- **CLEANING** – Never clean the phone with any chemicals or corrosives.

- HEARING AID – If a user has a hearing aid, carefully adjust phone volume and properly set the hearing aid sensitivity.
- ELECTRONIC MEDICAL EQUIPMENT – The telephone is a radio transmitter that might interfere with medical equipment and implants such as hearing aids, heart pacemakers, and insulin pumps, etc. The minimum distance of 15 cm between the phone and the implant is recommended. For more information, contact your doctor or a medical equipment manufacturer.
- ELECTRONIC EQUIPMENT - To avoid a risk of degaussing, keep the phone away from electronic devices.
- WATERPROOF – The telephone is not waterproof. Keep it dry at all times.
- DUSTPROOF – The telephone is not dustproof, it should not be used in places with a higher concentration of dust. Protect the phone against metal chips that might make the phone malfunction.
- DISPLAY SCREEN – never press hard the screen and never use sharp tools as doing so might damage the display screen.
- Never press battery contact pins with metal tools as it might cause an explosion.
- Never expose the phone to either low or high temperature, direct sunlight, or high humidity. Do not place your phone next to heating devices such as radiators, heaters, ovens, furnaces, camp fires, barbeque, etc.
- Protect your hearing!



Prolonged exposure to loud sounds might damage your hearing. Listen to music at a moderate level, and do not keep your phone too close to an ear, while using a

speakerphone.

6 GETTING STARTED

Prior to using the phone, a SIM Card must be installed. Be careful not to damage the card while inserting it.

Keep SIM Cards away from children.

6.1 SIM CARD AND BATTERY INSTALLATION

Prior to inserting the SIM Card, make sure the phone is switched off, and the battery is removed. The charger must be disconnected. To insert the SIM Card, first remove the battery as shown in drawings below and follow the instructions:

- When the phone is switched off, slide the battery cover downwards, and remove it.
- Remove the battery lifting it up with your fingernail from the topside of the phone
- Insert the SIM Card into the slot, with metal contact pins facing downwards. Make sure the card notch goes downwards.

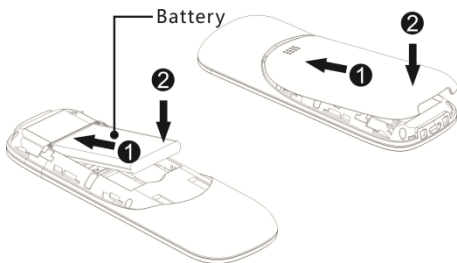

- There is a spot for the MicroSD memory card under the SIM Card slot. Insert the card into the slot. You can install a memory card up to 16GB on the phone.

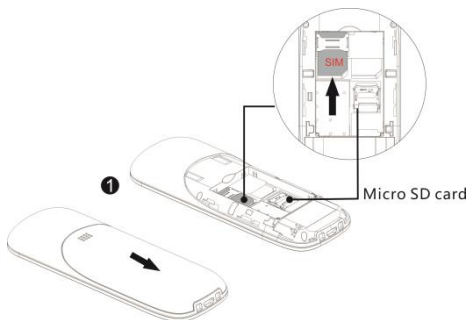

Be careful while using a memory card especially while inserting and uninstalling it. Some memory cards require formatting on the computer prior to the first use. Regularly, make copies of data stored on cards used in other devices, if you use SD cards! Misuse or other factors might damage the card or cause data to be lost.

Battery installation:

- Insert the battery so that contact pins +/- will face downwards.
- After inserting the battery, put the battery cover back and slide it upwards.

Charging the battery:



Important! You should use the charger included in the set. Using other chargers might damage the phone and will void the warranty.

Never connect the charger if the back cover is removed.

To charge the phone:

1. Plug the charger into a power outlet.
2. Plug the charger into the jack located at the bottom of the phone. A message about charging will appear on the display, and the bars in the battery icon will keep blinking as long the battery charging is in process.
3. As soon as the battery is fully charged, unplug the charger from the power outlet, and then cable from the phone.

If the process of charging is complete, there will be a message on the display „Battery fully charged”, and the battery icon will stop blinking.

6.1.1 **DESKTOP CHARGER**

In case of using a desktop charger, first you need to connect the charger with a desktop charger, and then plug it into a power outlet. To charge the battery, all you need to do is to place the phone on the desktop charger with contact pins downwards.

Important:

- Prior to charging make sure the battery is installed correctly
- Never remove the battery while charging – you might damage the phone
- If the voltage is too low for the phone to work properly, a warning message will appear on the display that the phone will be automatically switched off, and the phone will be switched off.
- If the battery is deeply discharged, it might take up to several minutes for the message to appear after the charger is plugged in.
- If the phone was not used for a long time, the battery might be so called “deeply discharged”; to recover a deeply charged battery you should leave the battery connected although there is no message on the display. It might take up to an hour for the message to appear.

7 LOW BATTERY ALERT

The phone will beep (if warning alerts are enabled in profile) and a message „Battery discharged” will appear on the

display, if the battery level is too low. The icon  will appear on the screen. If you see such a message, charge the battery.

8 PHONE DESCRIPTION

1	Speakerphone	8	Right Function Key - RFK
2	Display	9	Green receiver – making phone calls
3	Key Up	10	Red receiver – ending phone calls/returning to the homepage
4	Key Right	11	Key OK
5	Key Left	12	Numeric Keypad
6	Key Down	13	Key Radio FM
7	Left Function Key - LFK	14	Audio Player Key

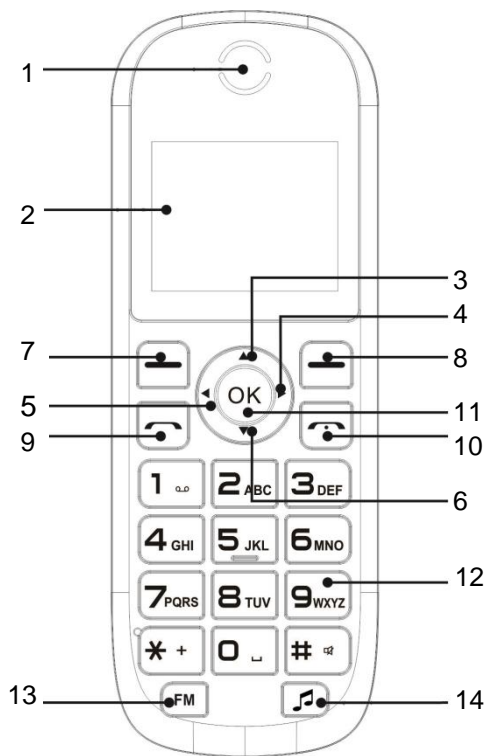







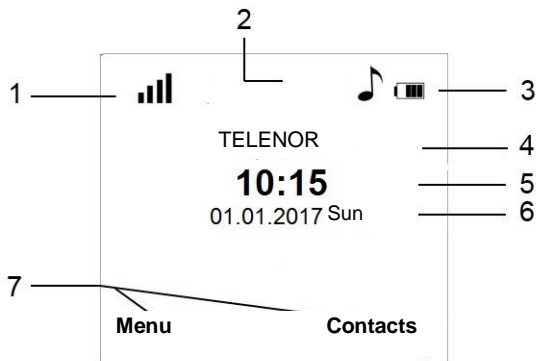

Key Basic Functions

Key		Function
Red Receiver		Press: return to idle mode; ending a phone call Press & hold: switchin on/off the phone
Green Receiver		Press: making phone calls; in Idle mode entering Call Log;
Nav. Keys	Up	Keypad Volume Up
	Down	Keypad volume down
	Left	Calculator
	Right	Alarm
	LFK	Function as shown on the display
	RFK	Function as shown on the display
	1	Press: digit 1 Press & Hold: voicemail
	2-9	Press: digits 2 to 9 Press & hold: dials a preset speed dial number
	*	Inserting symbols: *, +, P, W. While typing a text message: special characters
	#	Press: Change of text input mode, in Idle mode – entering the symbol # Press & hold: enable/disable Silent mode
	Key OK	Confirmation key, in most case the same function as LFK

8.1 DISPLAY SCREEN DESCRIPTION



1. Network Signal
2. Icons presenting functions:

	Beep only		Unread Text Mssg
	Silent		Keypad Locked
	Alarm clock on		Roaming active
	Missed phone call		Signal strength
Icons might vary depending on the software version		* The icon  appears also in domestic roaming if the user uses a network of another service provider	

3. Battery level
4. Service Provider name.
5. Time.
6. Date.
7. Function keys description.

Important: to save energy, the display automatically turns off after certain time. To enable display backlight, press any key.

8.2 KEYPAD LOCK

To lock the keypad, in Idle mode press the Left Function Key, and then (*). To unlock the keypad, press the Left Function Key, and then (*). There is no need to unlock keypad to answer an incoming phone call.

Important: The keypad will lock (automatically or manually) only if the phone is in Idle mode.

9 USING MENU

To enter MENU, in Idle mode press the key **OK** or **Left Function Key**.

To move in MENU use keys **UP/DOWN**.

To confirm a selected function press the key **OK**.

To return to the previous MENU (go back), press the Right Function Key. To go to Idle mode, press the red receiver.

10 PHONEBOOK

10.1.1 SAVING NEW ENTRIES

There are two ways for you to save a new contact:

1. You can save a new entry from the list of missed and received phone calls. To do so, in Idle mode press the green receiver key, select the number you wish to save, and press „Options” (LFK). Select „Save in Phonebook”, press LFK, select the location to save it. Enter the name of the Contact. Press the LFK to save.
2. You can save a new Contact in Idle mode by entering the phone number you wish to save, and press „Options” (LFK). Select „Save in Phonebook”, press LFK, select the location to save the new Contact. Enter the name of the Contact. Press the LFK to save.
3. You can add a new entry directly to the Phonebook. To do so, in Idle mode press the Right Function Key, and then use the key **Up**, select **New Contact>Select**. Select the location you wish to save the Contact. Enter the name of the Contact, and then use the key **Down** to go to the text input field, enter the number, and press **Save (LFK)**.

10.2 VIEWING PHONEBOOK

Method 1

1. Go to MENU and select Phonebook
2. Enter the first letter of the Contact wish to view
3. The phone will go to the list of Contacts starting with this letter. Use the navigation keys UP/DOWN to scroll the list up and down.

by pressing „#” you will change the text input mode.

Method 2

1. In Idle mode press the RFK

2. Enter the first letter of the Contact you wish to view
3. The phone will go to the list of Contacts starting with this letter. Use the navigation keys UP/DOWN to scroll the list up and down.

by pressing „#” you will change the text input mode.

10.3 DELETING ENTRIES

10.3.1 DELETING A SINGLE CONTACT

If you wish to delete a single Contact from your phone or the SIM Card, do as follows:

1. In MENU select Phonebook
2. Select the Contact you wish to delete, press Options->Delete
3. Press the LFK to confirm.
select Options->Delete Few>Yes

10.3.2 DELETING ALL CONTACTS

If you wish to delete all Contacts from your phone or the SIM Card, do as follows:

1. In MENU select: Phonebook->Options->Settings->Delete All Contacts
2. Select if you wish to delete all Contacts from the SIM Card or memory phone, and press Yes to confirm.

10.4 COPYING CONTACTS

10.4.1 HOW TO COPY A SINGLE CONTACT

To copy Contacts from the SIM Card to the phone, or from the phone to the SIM Cards, do as follows:

1. In MENU select Phonebook

2. Select the Contact you wish to copy
3. Press Options->Copy and select where you want to copy the Contact to, and press the Left Function Key.

10.4.2 HOW TO COPY ALL CONTACTS

If you wish to copy all Contacts from the phone or the SIM Card, do as follows:

1. In MENU select: Phonebook->Options->Settings->Copy All
2. Select the location for Contacts to copy to, and press Yes to confirm.

10.5 TRANSFERRING CONTACTS

You can transfer Contacts from the SIM Card to the phone memory or from the phone memory to the SIM Card. To do so, select MENU->Phonebook->Options->Settings->Transfer All. Then proceed like in point 8.4.2 on how to Copy All Contacts (see **point** Błąd! Nie można odnaleźć źródła odwołania.).

10.6 PHONEBOOK SETTINGS

10.6.1 MEMORY STATUS

This option enables you to check the SIM Card memory and the phone memory.

In MENU select->Phonebook->Options->Settings->Memory Status

10.6.2 SPEED DIAL

In MENU select: Phonebook->Options->Settings->Speed Dial->Status to enable or disable speed dialing. If speed dialing is enabled, and there are phone numbers assigned

to keys 2-9, press and hold a key to make a phone call with the number assigned to this key.

To assign a number to a key, in MENU select Phonebook->Options->Settings->Speed Dial.->Assign Keys. Then, select a key you wish to assign the number to, press LFK, select the phone number from the Phonebook, and press the LFK again.

10.6.3 ADDITIONAL NUMBERS

In MENU select Phonebook->Options->Settings->Additional Numbers->FDN->Mode to enable or disable Fixed Dialing.

To add a number to the Fixed Dial list, select Phonebook>Options->Settings->Fixed Dial->FD List. Then, press the LFK, enter the name and the phone number, and save by pressing the LFK.

11 MAKING PHONE CALLS

11.1 DIRECT DIALING

1. Enter the phone number you wish to dial.

For international phone calls you are required to dial „00” or „+” before the area code and the actual number. To enter „+” press the key „*” twice.

2. Press the green receiver to get connected with the selected number.
3. To end a phone call, press the red receiver key.

11.2 **DIALING NUMBERS FROM THE PHONEBOOK**

In Idle mode, press the red receiver key to enter the Phonebook. Use the keys UP/DOWN to select the Contact you wish to dial. If you want to go to a Contact starting with a letter U, press the key 8 twice. To dial the selected number, press the green receiver key..

11.3 **DIALING NUMBERS FROM THE CALL LOG**

Press the green receiver key when the phone is Idle mode to view the Call Log. Use the keys UP/DOWN to scroll up and down in the Call Log list. Press the green receiver, to make a phone call.

11.4 **SPEED DIAL**

If you assigned Contacts to keys 2-9, in Idle mode, press and hold the key with the number you wish to dial in order to make a phone call.

11.5 **ADJUST PHONE CALL VOLUME**

While talking on the phone, press the key RIGHT or LEFT to increase or decrease the conversation volume.

11.6 **OPTION WHILE TALKING**

To activate the speakerphone, while talking on the phone, press the Right Function Key. To deactivate the speakerphone mode, press the key again.

While having the conversation, press Options to enable additional features:

- Abort: aborts a phone call.
- End phone call: ends conversation.

- New phone call: allows you to make a new phone call.
- Phonebook: allows you to enter the Phonebook e.g to verify the phone number.
- Call Log: allows you to go over your Call Log.
- Messages: allows you to view read/saved messages.
- Voice recorder: starts recording of a phone conversation
- Mute: activate/deactivate the mike
- DTMF: allows to enable/disable DTMF
- Volume: adjusts the conversation volume.

11.7 CALL TRANSFER

It is a network service, and must be activated with your service provider. While having a conversation, press the LFK and select the option New call, enter the number, and press the green receiver. After the phone connection is established, press the LFK and select the option Transfer. Press the LFK to confirm, „Yes” to transfer the phone call.

11.8 ANSWERING PHONE CALLS

To answer an incoming phone call, press the green receiver key.

To reject an incoming phone call, press the red receiver key.

To silence an incoming phone call, press the right function key.

12 CALL LOG

To enter the Call Log, go to the main MENU and select Call Log, and then select:

Missed (to have a list of missed phone calls displayed). If you have missed a phone call, in Idle mode a receiver symbol will be displayed on the right side of the screen.

Dialed (to have a list of dialed phone calls displayed).

Answered (to have a list of answered phone calls displayed)

All (to have a list of all phone calls displayed)

To see the phone call details (duration, number of phone calls, etc.), press the key OK.

Important: To view Call Log, it is enough to press the green receiver key in Idle mode.

Color symbols notify you about a type of phone call.

After selecting a right phone call, press the Left Function Key to see additional options:

- **Preview**, lets you see details of the phone call,
- **Dial**, makes a phone call to this number,
- **Send a Message**, lets you send a text message
- **Save in Phonebook**, lets you add the number to the Phonebook
- **Add to Black List**, lets you add the number to the list of blocked numbers,
- **Edit before Dial**, lets you edit the number before you make a phone call
- **Delete**, deletes the item.

13 TEXT MESSAGES

The telephone allows you to send and receive text messages. The phone does not let you receiver multimedia messages.

If there is the icon  displayed on the screen, there is at least one unread message.

To enter **MENU Text Messages**, press the Left Function Key in Idle mode, and select Messages->Inbox.

13.1 CREATING & SENDING TEXT MESSAGES

1. Enter MENU, and then select: Messages->Create Mssg to open the text input field
2. Type your message.
 - **Changing of the text input mode:** to change the text input mode (digits, lower and upper case letters) press the key „#”, if you want to enter a symbol, press the key „*”.
3. Sending message: Press **Options>Send To** and select whether you want to manually enter the number or select it from the Phonebook. Select the number and press OK. If you want to send the text message to multiple recipients, you can select additional numbers. To send a text message, press **Options>Send**.
4. Saving message: To save the message you have just finished typing, press Options>Save. The message will be saved in the Draft folder. You might enable automatic saving of sent messages; to do so, go to MENU and select: Messages->Settings->Text Mssg->Save Sent Mssgs

13.2 READING & REPLYING TO TEXT MESSAGES

1. If there is an icon of unread message on the screen or you want to read previously read messages, in MENU select: Messages->Inbox. To read a message, press the OK key. While reading, you can use additional options by pressing the LFK.
2. The icon  next to a message means that this message has not been read yet.

By pressing „Options” while reading the message, you will display additional functions:

- Reply: send a text message to the Sender
- Call: call the Sender
- Forward: lets you forward the message to another recipient
- Delete: deletes the message
- Advanced: lets you use the number.

13.3 TEXT MESSAGES BOXES

13.3.1 INBOX

Received messages appear here.

Use the keys **UP** and **DOWN** to scroll up and down in the inbox.

13.3.2 DRAFTS

You can save unsent message in the „Drafts” folder. To do so, type your message, and after pressing the Left Function Key select „Save”.

Go to Drafts to send, delete or edit saved messages.

13.3.3 OUTBOX

If you fail to send a message, it will be saved in the Outbox.

13.3.4 SENTBOX

If you use the option „Save sent messages”, the sent messages will be saved in the Sentbox.

Use the keys **UP** and **DOWN** to scroll up and down in the inbox.

13.4 DELETING MESSAGES

To delete a selected message, go to message preview, and then to options, and select „Delete”.

13.5 MESSAGE SETTINGS

Go to MENU and select: Messages->Text Mssg Settings, and then select:

- SIM

- **Text Message Center Number:** is a go-between users while sending text messages. To send a text message from a cell phone, a correct Text Message Center Number must be saved on the phone.

Numer ten otrzymasz od usługodawcy.

- **Delivery Report:** You can choose to receive a delivery reports as soon as the text messages is delivered to the recipient (network service)

- **Reply via same center:** allows you to enable/disable such a function

- Memory Status

It allows you to check the memory status both on SIM Card and the phone.

- Save sent messages

It allows you to enable/disable saving of sent messages.

- Preferred memory

It allows you to select whether messages are to be saved on the phone or on the SIM Card.

13.6 VOICEMAIL

Voicemail is a network service that allows callers to leave a voice message when you cannot answer the phone call. To

learn more, contact your service provider. If you want to change your voicemail number, in MENU select: Messages>Settings->Text Mssgs->SIM->Voicemail, and enter the right number.

You can get the voicemail number from your service provider. To get connected with the voicemail it is enough to press and hold the key 

14 TOOLS

14.1 CALENDAR

To enable the calendar, in MENU select: Tools->Calendar. Use the keys Up/Down/Right/Left to move between days.

Press the Left Function Key to get additional options:

- Preview: allows to view a scheduled event,
- View All: allows to see all scheduled events,
- Add event: allows to add a new event.
- Delete event: allows to delete an event
- Go to date: enter the date you wish to go to
- Go to the current date: allows to go to the current day,
- Week view, changes the calendar view.

14.2 CALCULATOR

To enable the Calculator, in MENU select Tools->Calculator.

You can perform four basic mathematical operations: addition, subtraction, multiplication, and division.

Enter the first number by using the keys 0-9, then use the keys UP/DOWN/RIGHT/LEFT to select an operation, and enter the next number. Press OK.

14.3 **AUDIO PLAYER**

To use the audio player, MicroSD Card installation is required (not included in the package).

Using the player lets you play audio files. They must be stored in the folder My Music on the memory card. If there are some new files recorded, after turning on the player, select List ->Options->Refresh List. To start or pause playing, press the key OK. If you do not want the files to be played in the background, before leaving the player stop playing by pressing OK.

You can move between audio tracks by pressing the keys LEFT and RIGHT. To change playing options, select: List ->Options>Settings.

Press the key UP to change the playing options.

Adjust volume by pressing the key * and #.

The phone supports the WAV, AMR files.

14.4 **PHOTO VIEWER**

In MENU select: Organizer->Photo Viewer.

To use the photo viewer, MicroSD Card installation is required (not included in the package).

Using such an option, you can view a list of images saved on the memory card in the folder Photos. Some formats are not supported by the phone, the phone has also limitations if it comes to image size.

Press OK to open an image or Left Function Key Options->Preview to perform the following activities press the Left Function Key „Options“: Rotate Image, Use as, Details about Image.

14.5 VOICE RECORDER

You can record music or other sounds.

- Select in MENU: Organizer->Voice Recorder
- To start or pause recording, press OK.
- To end recording, press the Right Function Key.

The recordings are saved in the folder Audio. There is a possibility to play the recording. To do so, press the Left Function Key Options->List, play the recording and press the key OK.

14.6 FILE MANAGER

In MENU: Organizer->File Manager

Press the Left Function Key Options:

- Open: select to open a selected folder.
- Format: select to format a selected drive
- Details: select to display basic information.

After you open the folder, there are the following options under the Left Program Key:

- Open
- Create a Folder: select to create a new folder in a selected location,
- Rename: allows you to rename the folder
- Delete: allows to delete the folder
- Copy: copies a single folder
- Transfer: transfers a single folder

14.7 NETWORK SERVICES

14.8 SIM SERVICES

Apart from the device features, a SIM Card might offer you additional service. Names and options of such menu depend on the type of available service.

Service that require the Internet access might be unavailable.

15 ALARM

There are 5 independent alarms to select from. To enable alarm, in MENU select: Alarm. Select the alarm you want and press Edit. You can enable/disable alarm, set the time for alarm to go off, set the snooze, repeat, and alarm sound. If the phone is switched on, the alarm will work if there is enough battery. If the alarm goes off, press the Left Function Key to disable. Press the Right Function Key to snooze, the alarm will go off again after selected snooze time.

16 RADIO FM

The telephone has a built-in radio FM.

Warning: Reception quality depends on your location. Reception of radio stations might be influenced by various factors that might cause a low quality of reception; poor quality, however, is never a reason to file a complaint about the product.

To enable the radio, select in MENU: Radio FM. To enable/disable the radio, press the OK key. Before you switch off the radio, stop playing the radio by pressing the key OK, and then press the red receiver key.

Keys functions while playing the radi:

- RIGHT: next channel
- LEFT: the previous channel
- UP: increasing frequency by 0,1 MHz
- DOWN: decreasing frequency by 0,1 MHz
- #: volume up
- *: volume down
- Red receiver: return to menu
- Keys 1 – 9: selecting the radio station from the radio list of channels (radio channels must be saved)

17 SETTINGS

Select in MENU: Settings, and then:

17.1 SETTING DATE AND TIME

To set the date and time, select in MENU: Settings->Time & Date. Select „Time Zone”, to select a town you want, and then „Set Time/Date”, to enter time/date. Use keys Up/Down/Right/Left to move between time and date; use keys 0-9 to enter the date and time.

You can also set time format (12h or 24h), date format (DD/MM/YYYY, MM/DD/YYYY or YYYY/MM/DD) and date separator.

If the battery is removed, after placing back the battery you have to set the and time again (if they are not automatically taken from the network).

Option: Update after time zone change allows to enable/disable the function of automatic update after the time zone change.

Option Auto time change allows you to select whether after switching on the phone the time shall be automatically adjusted, after confirmation or it should not appear.

17.2 PROFILES

There are some profiles on the phone, for you to set a right profile for a given situation. You can activate and adjust each profile as per your needs, but the Silent profile. There are profiles: General, Silent, Outdoors.

In profiles, use the option Adjust to change:

- Ringtone type (single or repeated)
- Ringtone sound
- Ringtone volume
- Text message alert
- Text message alert volume
- Keypad beep
- Keys volume
- Enable/disable warning alert beeps.

In Idle mode press and hold the key # to enable the Silent profile, hold the key # again to return to the previous profile.

17.3 LANGUAGE

It allows you to change the Menu language. If you set a foreign language by mistake, to change it back to the language you want, in Idle mode press:

- 1x OK
- 2x UP
- 1x OK

- 2x DOWN

- 1x OK

select the language you want and press OK.

17.4 **DISPLAY SCREEN**

17.4.1 **WALLPAPER**

Select a wallpaper for the phone (it will work as a background for your screen in Idle mode).

17.4.2 **AUTOMATIC KEYPAD LOCK**

This feature allows to set time for the keypad to be automatically locked.

17.4.3 **BACKLIGHT**

Display screen backlight: allows to set time of backlighting the display screen.

17.4.4 **BRIGHTNESS**

This function allows to set brightness of the display screen. Use the key LEFT/RiGHT to adjust brightness.

17.5 **SECURITY SETTINGS**

17.5.1 **PIN CODE**

If this function is enabled, the phone will ask you to enter the PIN Code every time the phone is switched on, and you can change the PIN Code.

17.5.2 **PHONE SECURITIES**

You can enable locking the phone. Every time you switch on the phone, entering lock code will be required. Default code is 1122.

17.6 **CALL SETTINGS**

17.6.1 **NUMBER WITHHOLD**

It is a network service. If your provider offers such a service, a configuration will be required. This feature allows you not to display your own number while calling.

Select „Gets Network”, „Withhold number” or „Send number” and press „Ok”.

17.6.2 **CALL WAITING**

It is a network service. If your provider offers such a service, a configuration will be required.

After entering MENU and entering option: Settings->Call Settings->Call Waiting you can check availability and decide if you want to enable such a feature.

If Call Waiting is enabled, and the User is talking on the phone, he/she will be notified about any other incoming phone call by a special alert of a second call. You can answer the second incoming phone call and suspend the first one.

17.6.3 **CALL FORWARDING**

It is a network service. If your provider offers such a service, a configuration will be required. The User might direct incoming phone calls to be forwarded directly to voicemail or to any other number.

1. To select Call Forwarding, in MENU go to Settings->Call Settings->Call Forwarding
2. Then select when you want to forward phone calls from the available list:**1 All phone calls** (forwards any incoming phone calls received by your number) **2 When unavailable** (forwards phone calls if your phone is switched off or out of reach) **3 When I don't answer** (forwards incoming phone calls if you don't answer them) **4 When busy** (Forwards incoming phone calls if you are currently talking on the phone) **5 Forward any data connections** **6 Abort any forwards.**
3. Press **Enable** and enter the number you wish to forward incoming phone calls to, to enable such a service, or **Disable** not to use it.
To see what is the current status of this feature, go to **Check Status**

17.6.4 CALL BARRING

It is a network service. If your provider offers such a service, a configuration will be required. This feature allows you to restrict certain types of phone calls.

1. Go in MENU to:
Settings->Call Settings->Call Barrings
2. Select type of phone calls you wish to restrict from the list. You can restrict any outgoing phone calls, outgoing international, international (except to home), any incoming phone calls and incoming roaming phone calls. You can also update your lock password.

17.6.5 BLACK LIST

You can add a number to a black list. If such a function to block incoming calls and text messages is enabled, (selected option Reject) any incoming phone call and a

message from the blacklisted number will be automatically rejected.

17.6.6 CALL DURATION REMINDER

You can select phone call duration feature. You will hear a beep every time you have selected (31-60sec) or after certain time has passed (2-3000sec) to notify you about phone call duration.

17.6.7 AUTO REDIAL

If this feature is enabled, when you fail to make a phone call, the phone will automatically redial the number.

17.6.8 ANSWERED PHONE ALERT

If this feature is enabled, after the call has been successfully made, you will hear a notification alert.

17.6.9 ANSWERING CALLS

You can set any key to answer a phone call if pressed.

17.7 NETWORK SETTINGS

Network Setting: you might select a service provider manually or automatically.

17.8 FLIGHT MODE

You can enable a flight mode. If this mode is enabled, there is no connection with the GSM network, making phone calls and sending/receiving messages is not possible.

17.9 RESTORE FACTORY SETTINGS

Use this option to restore factory settings. Select in MENU: Settings->Restore Factory Settings, and then enter the security code. To finish, confirm by pressing the green receiver.

Warning: Default security code is 1122

18 COMPUTER CONNECTION

You can connect the phone to a computer by a USB cable, and you can copy and transfer files between the phone and the computer.

To connect:

- Insert the USB cable to the telephone,
- insert the other end of the cable to a computer jack,
- You will see a message on the phone screen: „Mass Memory Device” and “Port COM. Select the Mass Memory Device.

19 FAQ (TROUBLESHOOTING)

Only qualified service workers are authorized to repair your phone. Unauthorized repairs and modifications will void the Manufacturer's warranty!

„Can't make a phone call”	Make sure the number you are dialing is correct. If you make an international phone call, dial a country code before the actual number (e.g. 0049 or +49 for Germany). If you have a prepaid card, make sure there are sufficient funds available on the card to place a phone call.
---------------------------	---

„No SIM Card, emergency calls only (112)“	Make sure the SIM Card is installed correctly
„The phone does not work, the phone does not charge when plugged in“	<p>The phone might be switched off; switch on the phone by pressing and holding the Make Call key (green receiver) for about 3 seconds.</p> <p>If you have not used the phone for a long time, the battery might be “deeply-discharged”. To recover a deeply-discharged battery leave your charger plugged in, although there might be no image on the display.</p>
„Can I make a phone call while abroad“	If you are out of the country, the phone logs on automatically to the foreign network, if ROAMING is enabled. To learn more, contact your service provider
„Can I make an emergency call if there is no reception or if there are no funds on my account?“	<p>If you are in the area with no reception of any network, no phone calls can be made.</p> <p>If you have no funds available on the account, emergency call to 112 can be made</p>

<p>„How to get most of my reception?“</p>	<p>If there is a message „Does not work“ on the display, it means there is no signal or no funds available on your account. In such a case, only making emergency calls to 112 will be possible if the user is within the network of other providers.</p> <p>Places such as buildings reduce signal strength, therefore you should get closer to a window or relocate to an area not surrounded by many buildings.</p>
<p>„There is a message on the display „Press * to unlock“, keys don't work“</p>	<p>Keypad lock is enabled. Unlock the keypad by pressing the Left Function Key, and then press * (star).</p>
<p>„What is a Text Message Center“</p>	<p>It is the service provider's center number storing all text messages. The number is stored on the SIM card, but you can change the number in the phone MENU and enter another number.</p>
<p>„When the fee for making a phone call is charged?“</p>	<p>A fee for making a phone call is charged as soon as a phone call is made. To learn more about charging details, contact your service provider.</p>
<p>„How to make sure a text message has been delivered to the recipient?“</p>	<p>Enable Delivery Report option. As soon as the text message is delivered, you will get a return message (network service).</p>

20 WARRANTY TERMS

The phone is covered by warranty; to get warranty, a proof or purchase is required.

There is a charge for repairing phone defects arising from malfunction, electrostatic discharge, and lightning strikes. Any attempts to repair or modify the phone on your own will void your warranty.

The above is presented for information only.

21 BATTERY INFORMATION

There is a battery on the phone that might be charged and recharged with the charger included in the set.

The phone lifetime depends on various working conditions. The distance from the transceiver station, number and length of phone conversations significantly reduce its lifespan. While moving, the phone switches between transceiver stations and it also reduces the lifespan of the battery.

After multiple charges and discharges, it is natural for the battery to lose its qualities. If significant loss of efficiency is observed, you should get a new battery.

Use only chargers recommended by the Manufacturer.

Never leave the charger connected for longer than 2-3 days.

Never keep the phone in places with excessive temperature. It might negatively impact the battery and the phone.

Never use the phone if it is visible damaged. It might cause short circuit and might damage the phone. The battery should be inserted in accordance with polarization.

Leaving the phone in places with excessively high or low temperature will increase its lifetime. The battery should be stored in temperature 15°C - 25°C. If you insert a cold battery to the phone, the phone might not work properly and there is a risk of damage.



Old batteries pose environmental risks. They should be disposed of at a special place in a special container in compliance with current regulations. Never throw old batteries or chargers to municipal solid waste, they

should be collected for disposal.

NEVER PUT BATTERIES NOR CHARGERS INTO FIRE!!!

22 SAR INFORMATION

This telephone meets all international standards pertaining to the impact of radio waves. The product both receives and emits radio waves. It is designed not to exceed any limits pertaining to impact of radio waves recommended by international guidelines. These guidelines were developed by the International Commission on Non-Ionizing Radiation Protection (ICNIRP), an independent scientific organization with a safety margin to protect all people regardless their age and health condition. Such guidelines use a unit of measurement called Specific Absorption Rate (SAR) – actual absorption.

As recommended by ICNIRP, the border value of SAR for portable equipment is 2,0 watts per kilogram (W/kg). SAR value is determined at the maximum transmit power; the actual SAR value while the product is working is usually lower than the indicated level. Such discrepancies result from automatic changes in device power necessary to

ensure that the device operates at a minimum power level required to be connected with network.

Although SAR values might vary for different models of phones or even for different positions of the same model, they are all compliant with regulations pertaining to safe level of radiation.

According to WHO current research, there is no need to apply any special restrictions in using portable devices.

According to WHO, in order to reduce radiation, a length of conversation should be reduced, or headset or speakerphone should be used, or the phone should not be held in proximity to head or body.

The highest SAR value taken in tests	
SAR – device next to head	0.841 W/kg 10g (GSM900) 0.176 W/kg 10g (GSM1800)
SAR – device next to body	1.123 W/kg 10g (GSM900) 0.544 W/kg 10g (GSM1800)

SAR values might also vary due to various reporting and testing requirements in different countries as well as to different frequencies in a certain network.

23 PROTECT YOUR ENVIRONMENT

Important: The phone follows the European Waste Electrical and Electronic Equipment Directive 2002/96/EC (WEEE) and the Polish Act on Waste Electrical and Electronic Equipment.



Such a logo tells us that the equipment, after use, must not be disposed of in the normal waste stream.

Important: Never throw your phone & accessories to municipal solid.

Proper handling of waste electrical and electronic equipment helps to avoid health and environment hazards arising from presence of hazardous components and from improper storage and use of such equipment.

24 EC DECLARATION OF CONFORMITY



MaxCom S.A.
ul. Towarowa 23a | 43-100 Tychy

Tel: +48 32 327 70 89
Fax +48 32 780 30 00

office@maxcom.pl
www.maxcom.pl

EC Declaration of Conformity 04/2017/EC

Maxcom S.A., ul. Towarowa 23a, 43-100 Tychy declares under our sole responsibility that:

Dual-band GSM cell phone for use in public 900/1800MHz networks

Maxcom MM35D

complies with the Directive of the European Parliament and the Council 2011/65/EU of 8 June 2011 on the restriction of use of certain hazardous substances in electrical and electronic equipment and meets all the essential requirements of Directive 1999/5/EC - R&TTE (Radio Equipment and Telecommunications Terminal Equipment).

This device is compliant to harmonized standards indicated below.:

Safety:

EN 60950-1:2006+A11:2009+A1:2010+A12:2011 +A2:2013

Health (SAR):

EN 50360:2001+A1:2012; EN 62209-1: 2006;

EN 62209-2:2010; EN 50566:2013/AC:2014

EMC:

EN 301 489-1 V1.9.2; EN 301 489-7 V1.3.1

Radio

EN 301 511 V12.1.1

The conformity assessment procedure referred to in Article 10 and detailed in Annex [IV] of Directive 1999/5/EC has been carried out with involvement of the following institutions:

Phoenix Testlab: Notified body: 0700

Expertise No. 17-210439

Technical reports and examination certificates:

Report No.: ASTS1702015A01; STS1702015A02; STS1702015H01 (SAR)

Report No.: AGC00200161101EE01; AGC00200161101EE11

Report No.: AGC00200161101EE04; AGC00200161101EE03

The last two digits in which the CE marks have been plotted: 17

Tychy, 31 March 2017
place, date

42-100 TYCHY, ul. Towarowa 23a
tel. 32/3277089, fax 32/3277860
NIP: 646 25 27 264 REGON: 277703221

Adam Grzyś

name of authorized person

Complains or device defects can be reported via website:

<http://www.comtek.co.uk/maxcom-rma-service/>

Mobile service address:

Comtek Network Systems
Unit 108, Tenth Avenue (Zone 3)
Deeside Industrial Estate
Deeside, Flintshire CH5 2UA

If any technical assistance is required, please contact the technical department as +48 32 325 07 00 or send an email to:

serwis@maxcom.pl

Our website:

<http://www.maxcom.pl/>

**MAXCOM S.A.
ul. Towarowa 23a
43-100 Tychy
Poland**

tel.: +48 32 327 70 89

fax: +48 32 327 78 60

www.maxcom.pl

e-mail: office@maxcom.pl

